



**UVC LED Emitter: “Devils Eye” Flat lens**  
**MLUVC-P102-xmW-120**



“Devil's Eye” :  
 UVC chip in center  
 Blue phosphor around

**Key Features**

- AlN substrate, low thermal resistance (5°C/W)
- Eutectic soldering for die attach
- Wavelength range: 270-280 nm
- Quartz flat glass, light output angle, full width at half peak 120°
- Hermetic sealing
- Lead (Pb) free RoHS compliant
- Silver plated substrate for more light output

**Typical Applications**

- Sterilization for medical use
- Disinfection of drinking water
- Air purification

**1. UVC Wavelength (Note 1)**

Minimum (nm)	Maximum (nm)	Typical (nm)	Peak width
270	280	275	11

**2. Product Family (Photon Wave chips) (Note 1)**

Product #	PW Chip Spec	Forward current (mA)	Forward voltage (V)	Typical Output Power (mW)	Irradiance (mW/cm <sup>2</sup> ) at 20 mm
MLUVC-P102-3mW-120	PCD-02-V1	20	5.0 - 7.0	3.5	
MLUVC-P102-15mW-120	PCD-10-V1	100	5.0 - 7.0	15	0.42
MLUVC-P102-22mW-120	PCD-15-V1	150	5.0 - 7.0	22	
MLUVC-P102-50mW-120	PCD-35-V1	350	5.0 - 7.0	50	

### 3. Package Dimension (mm) (Note 2)

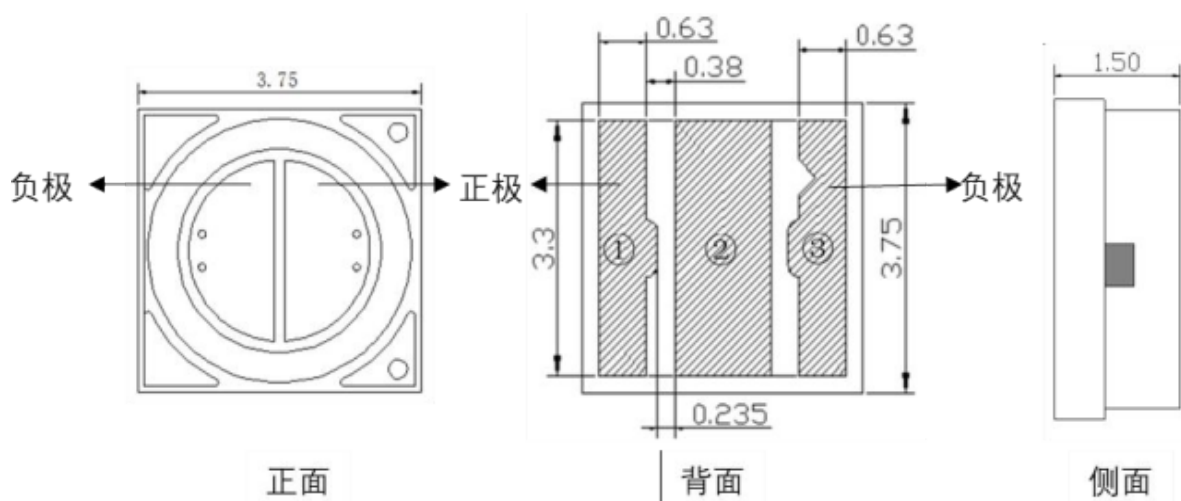

### 4. Electrical connectivity

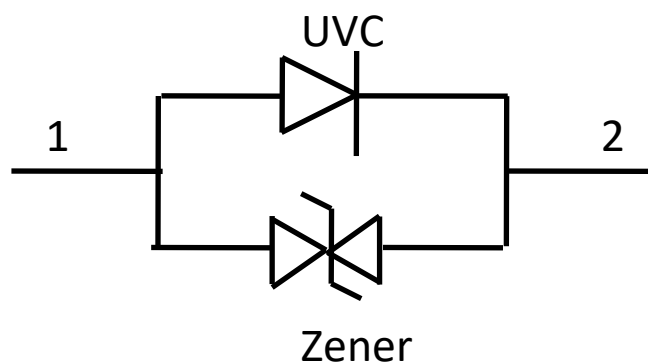

#### Note 1

1. Wavelength, forward voltage, output power are measured at 25°C.  
Also, measurement tolerance:
  - Wavelength:  $\pm 3$ nm
  - Forward voltage:  $\pm 5\%$
  - Output power:  $\pm 10\%$
2. Dimensional tolerance:  $\pm 0.2$  mm.

## 5. Absolute Maximum Rating

Parameters	Product #	Maximum Value or Range
Forward current (mA)	MLUVC-P102-3mW-120	40
	MLUVC-P102-15mW-120	150
	MLUVC-P102-22mW-120	225
	MLUVC-P102-50mW-120	500
Junction Temperature (°C)	ALL	85
Operation Temperature (°C)		-30 <=> 60
Storage Temperature (°C)		-40 <=> 100

## 6. Characteristic Curves

< Forward Voltage vs. Forward Current >

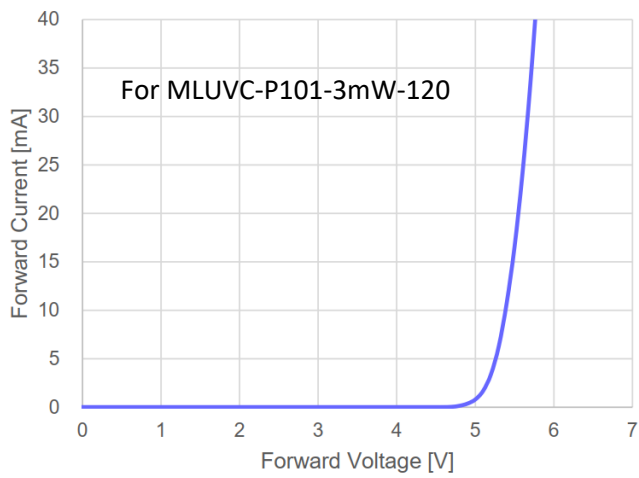

< Forward Current vs. Relative Radiant Flux >

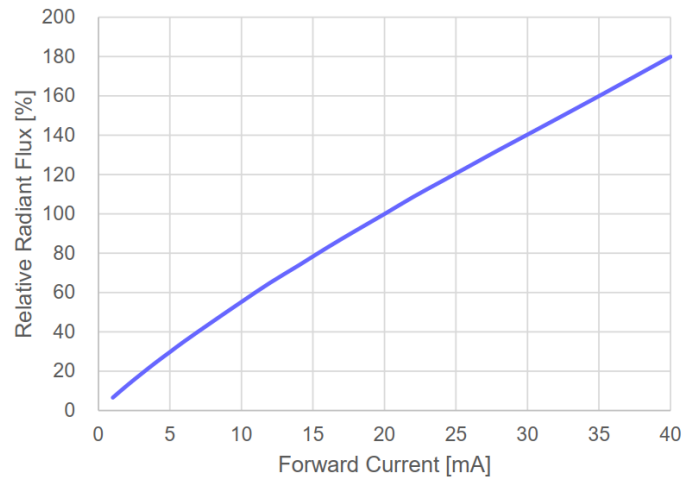

< Spectrum,  $I_F = 20 \text{ mA}$  >

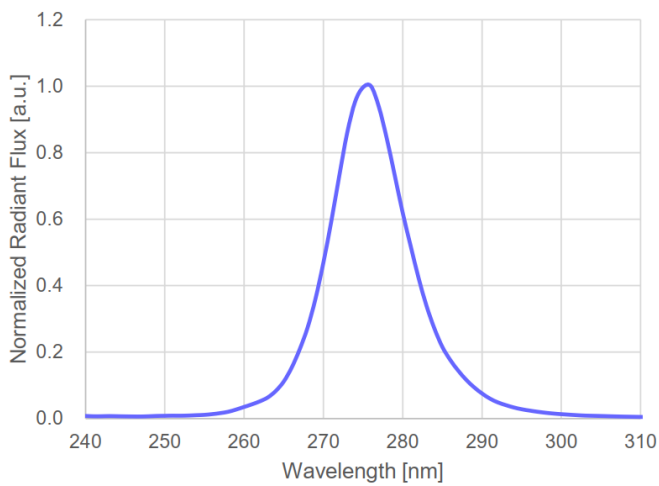

< Forward Current vs. Relative Radiant Flux >

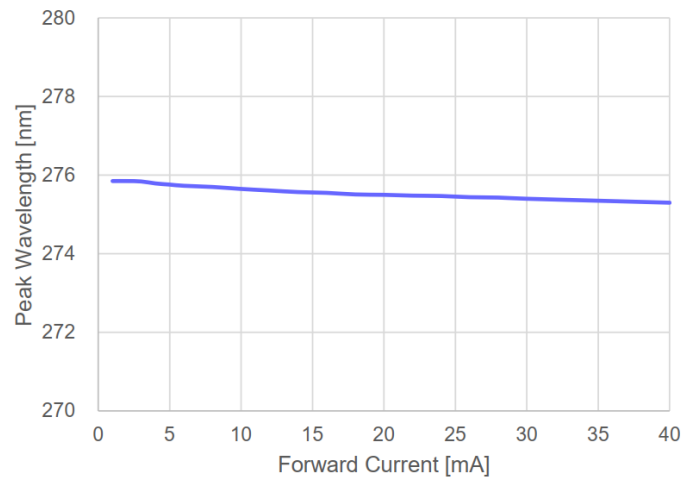

< Ambient Temperature vs. Forward Voltage Shift >

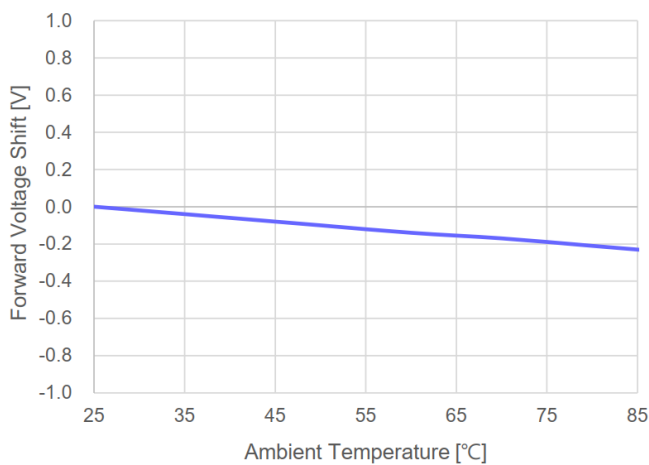



## 7. Binning

### Forward voltage (Vf) Binning

Vf Bin	Vf at typical If (V)	
	Min	Max
V1	5.0	5.5
V2	5.5	6.0
V3	6.0	6.5
V4	6.5	7.0
V5	7.0	7.5

1. The typical current means the current listed for each product # on Page 1.
2. Tolerance on each Vf bin is  $\pm 0.1$  V.

### Peak wavelength (Wp) Binning

Wp Bin	Wp at typical If (nm)	
	Min	Max
W1	270	275
W2	275	280

1. The typical current means the current listed for each product # on Page 1..
2. Tolerance on each Wp bin is  $\pm 3$  nm.

### Radiant power (Wp) Binning

$\Phi_e$ Bin	$\Phi_e$ at typ. If (%)	
	Min	Max
X1	65	73
X2	73	85
X3	85	100
X4	100	

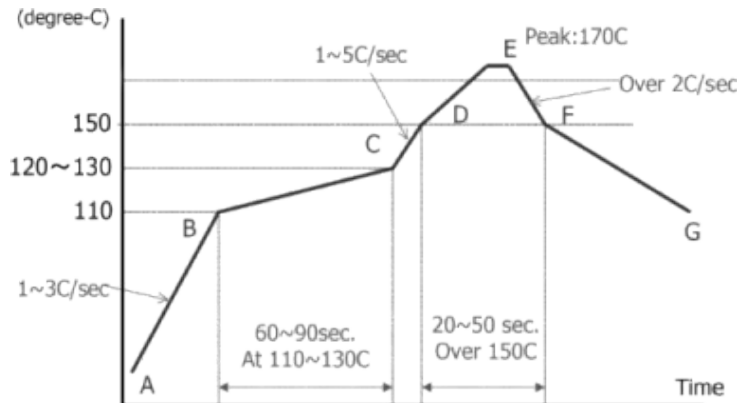

1. The typical current means the current listed for each product # on Page 1.
2. Power is binned according to percentage of the specified power for each product # on Page 1.

## 8. Recommended reflow profile

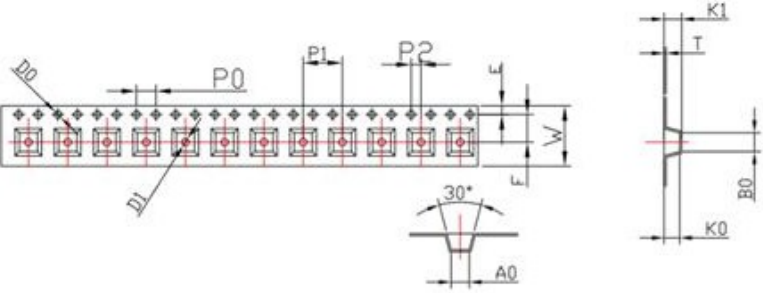
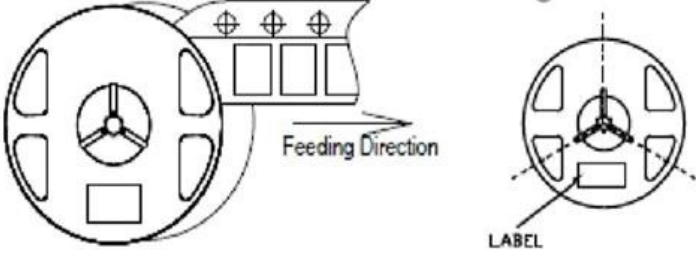

Low temperature solder paste should be used for reflow soldering, the peak temperature should not be greater than 170 °C, the peak time should be controlled at about 20 seconds, and the reflow time should not be greater than 5 minutes. Tin bismuth / tin silver bismuth series pastes are recommended, such as Sn42 / Ag1.0/Bi57.

## 9. Packing

Tape	 <table border="1" data-bbox="539 772 1125 945"> <tr> <td>symbol</td> <td>AO</td> <td>BO</td> <td>KO</td> <td>PO</td> <td>P</td> <td>P2</td> <td>长度/盘</td> </tr> <tr> <td>Spec</td> <td>3.90±0.1</td> <td>3.90±0.1</td> <td>1.60±0.1</td> <td>4.0±0.10</td> <td>8.0±0.1</td> <td>2.00±0.10</td> <td>400M</td> </tr> <tr> <td>symbol</td> <td>W</td> <td>T</td> <td>E</td> <td>F</td> <td>D</td> <td>D1</td> <td>元件/盘</td> </tr> <tr> <td>Spec</td> <td>12.0±0.3</td> <td>0.30±0.05</td> <td>1.75±0.10</td> <td>5.5±0.1</td> <td>1.50<sup>+0.1</sup><sub>-0.1</sub></td> <td>1.50±0.10</td> <td></td> </tr> </table>	symbol	AO	BO	KO	PO	P	P2	长度/盘	Spec	3.90±0.1	3.90±0.1	1.60±0.1	4.0±0.10	8.0±0.1	2.00±0.10	400M	symbol	W	T	E	F	D	D1	元件/盘	Spec	12.0±0.3	0.30±0.05	1.75±0.10	5.5±0.1	1.50 <sup>+0.1</sup> <sub>-0.1</sub>	1.50±0.10	
symbol	AO	BO	KO	PO	P	P2	长度/盘																										
Spec	3.90±0.1	3.90±0.1	1.60±0.1	4.0±0.10	8.0±0.1	2.00±0.10	400M																										
symbol	W	T	E	F	D	D1	元件/盘																										
Spec	12.0±0.3	0.30±0.05	1.75±0.10	5.5±0.1	1.50 <sup>+0.1</sup> <sub>-0.1</sub>	1.50±0.10																											
Wheel																																	
ESD bag																																	

### Note

- 1 The camber angle of the carrier is not more than 1 mm / 100 mm, and the length is 250 mm;
- 2 All dimensions meet eia-481-b requirements;
- 3 Materials: conductive polyester polystyrene plastic.

## 10. Reliability Testing

Test	Condition	Failure criteria	Failure Rate
Normal operation	T =25°C, specified current , continue 1000 hour	No light output	0/35
Thermal shock	-40°C-120°C.500 cycles, 15min/cycle	No light output	0/35
Reflow	Peak temp<170°C, 10 zone reflow oven, 1 time	No light output	0/100
ESD, humen body model	R=1.5kΩ, C=100pF, Voltage level=2kV	No light output	0/100

## 11. Safety and Risk



### Note

1. All assembly workers, observers and bystanders must have eye and skin protection;
2. It is forbidden to observe with naked eyes (including through microscope) and handle deep UV LED naked in operation;
3. Do not touch the optical structure of the deep UV lamp bead;
4. This product is a humidity sensitive product. The recommended storage temperature is 18 °C~ 30 °C, and the humidity is 30% ~ 60%, Sealed storage: in order to ensure the product quality, if the outer packing bag is not opened, it is recommended to use it within one year after leaving the factory; if the outer packing bag is opened, it is recommended to use it within 24 hours; if it is more than 24 hours, it needs to be sealed and stored again; before the next use, it is recommended to take dehumidification measures: temperature: 65 °C time: 5h.